

Existing Rules and Regulations: Landscaping Section

L. LANDSCAPING

1. All landscaping performed on/at any unit/parcel, other than putting down sod or the planting of flowers, requires a permit signed by the Park Manager. Nothing will be placed in such a manner as to interfere with utility maintenance, including the reading of electric meters, or with an adjacent unit owner's view or ability to wash or perform maintenance on his/her principal camping facility (motor home, travel trailer, or park model). No permit will be issued for any landscaping which is not in good taste or is not in keeping with the overall pleasing esthetic qualities of the Park or poses any hazard (i.e., restricts visibility necessary for safety). This rule pertains to landscaping and is distinct and separate from rules relating to construction.

2. Owners shall protect (against weed trimming) all shrubbery and trees with a protective ring of concrete, metal, plastic or mulch. Owners shall protect unit skirting by providing a barrier of some type. Trimming will not be done along unprotected skirting because of potential damage. Owners shall also be responsible for providing protection for all exposed wires by enclosing them in conduit

Proposed Rules and Regulations: Landscaping Section

L. LANDSCAPING

1. All landscaping performed on/at any unit/parcel, other than putting down sod or the planting of flowers, requires a permit signed by the Park Manager. Nothing will be placed in such a manner as to interfere with utility maintenance, including the reading of electric meters, or with an adjacent unit owner's view or ability to wash or perform maintenance on his/her principal camping facility (motor home, travel trailer, or park model). No permit will be issued for any landscaping that is not in good taste, is not in keeping with the overall pleasing esthetic qualities of the Park, or poses any hazard (i.e., restricts visibility necessary for safety). This rule pertains to landscaping and is distinct and separate from rules relating to construction.

2. For landscaping near traffic signs, roads, and intersections, additional care must be taken. No landscaping is permitted to be taller than 36 inches in the vicinity of any traffic signs. Landscaping, such as bushes and trees must be kept trimmed back to the road edge and not extend into the roadway from the road surface up to 11 feet from the road surface. At intersections, a clear visibility triangle must be maintained, with no landscaping between 36 inches and 11 feet measured from the road surface. The triangle is formed by extending the roadway edge of pavement lines to a point where the lines intersect each other (point A); and from point (A), measuring to a point 20 feet along both lines points (B and C). The clear visibility triangle is defined as shown in the following image:

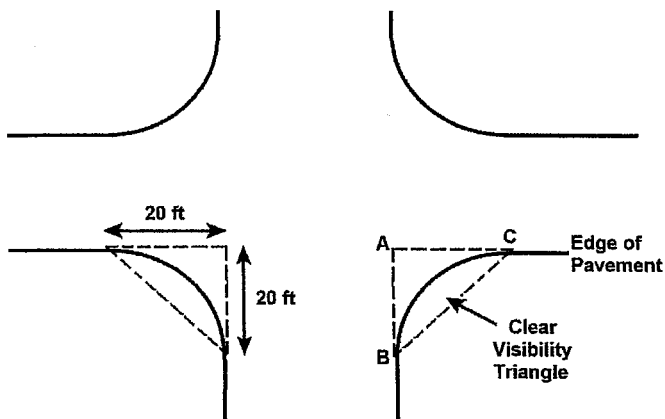

3. Owners shall protect (against weed trimming) all shrubbery and trees with a protective ring of concrete, metal, plastic or mulch. Owners shall protect unit skirting by providing a barrier of some type. Trimming will not be done along unprotected skirting because of potential damage. Owners shall also be responsible for providing protection for all exposed wires by enclosing them in conduit